

KSK screw classifier

for the solid-liquid separation of grit or other sediments

KUHN KSK screw classifier

The separation of sediments into solid and liquid components using the **KUHN** KSK screw classifier amounts to a sensible and secure investment.

The machines distinguish themselves significantly with a high separation capacity, low energy requirement and a high degree of operational safety with low maintenance requirement.

Operation

The sediment-liquid mixture is fed into the inlet flange pipe of the **KUHN** KSK screw classifier. The tank construction with its fixtures is designed in such a way that an optimal separation capacity is achieved.

The fluid is carried via the discharge/overflow channel to the drain connection. The floating matter is trapped by the scum baffle and, together with the sediments, transported and discharged from the liquid area through the shaftless screw classifier.

The static dewatering of the adjustable sediments as well as the separation capacity are assisted by a discontinuous operation.

The **KUHN** screw classifier can be equipped if requested with a border trinkets sensor. Hereby the stiff, on time dependent company is being transformed into flexible, independent of demand company. Only if there is enough sediment, the extruding process is being released. Besides a significant reduction of operating time the durability is being raised and the operating expenses are being minimized.

Design (Technical features)

The **KUHN** KSK screw classifiers consist mainly of the sedimentation tank and the internal shaftless screw classifier.

The machine is supported by a support structure made of profile steel. The drive is provided by an attached offset geared motor.

The upper area of the sedimentation tank is fitted with an influent pipe and a drain connection. Cover plates with a hinged control opening are mounted to provide an enclosure. An internal discharge/overflow channel with forward-placed scum baffle is fitted. The inclined shaftless screw classifier transports the sedimentary components to the discharge outlet above.

The superior design of our **KUHN** KSK screw classifiers ensures an optimal operation, both in an ecological and economical sense, and guarantees a long-term return on your investment, owing in part to the following advantages:

- Avoidance of turbulence which can affect the sedimentation
- High separation capacity due to our special construction principle
- Low energy requirement
- Replaceable wear liners
- High degree of operational safety due to robust design and high-quality materials
- Low maintenance requirement
- Large inspection opening
- Additional possibilities for emptying
- Holding back of the floating matters

Options

- Limit threshold dependent deposition of sand by a vibration switch

For extended transport of the separated material further products are available. Please note the following:

- **KUHN** KSF spiral conveyor
- **KUHN** KSW-T dry-loaded grit washer



KSK screw classifier

for the solid-liquid separation of grit or other sediments

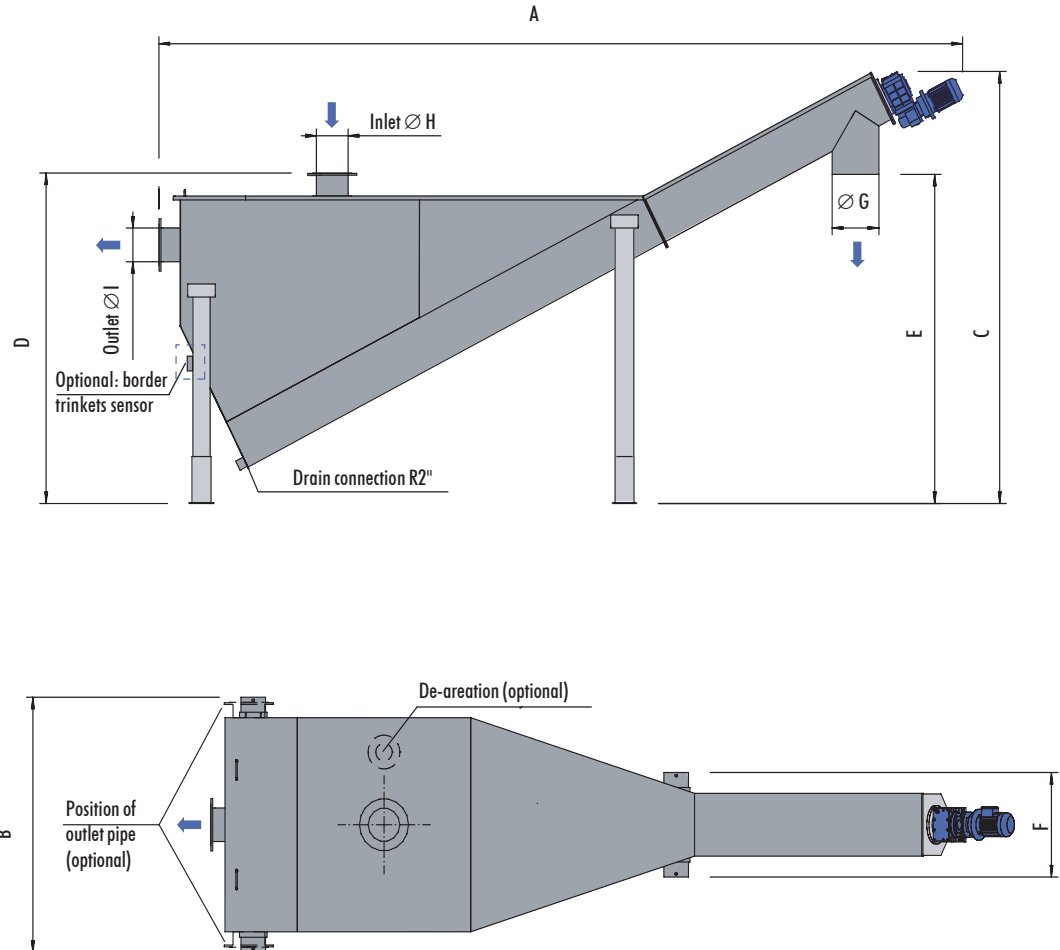

Dimensions in mm.
We reserve the right to make technical alterations.

Type	Feed rate [l/s]	A	B	C	D	E	F	Ø G	Ø H	Ø I	P _n [kW]
KSK 190	10	4270	1200	2255	1665	1755	525	DN 200/ 219.1	DN 150/ 168.3	DN 150/ 168.3	0.55
KSK 290	20	5590	1660	2850	2105	2145	680	DN 300/ 323.9	DN 200/ 219.1	DN 200/ 219.1	0.75
KSK 390	35	7100	2060	3500	2505	2500	850	DN 400/ 406.4	DN 250/ 273	DN 260/ 273	1.5

Drive

Index of protection IP55 (explosion protection possible)

Materials

Motors/Fittings commercial materials
 Container/Conveyor trough AISI 304 stainless steel
 Conveyor screw special steel

Other materials on request.